

THE BIG BANG
5C30.20
POWER SUPPLY @ REST:

**!!DANGER!!
HIGH VOLTAGE!
USE WITH EXTREME
CAUTION!**

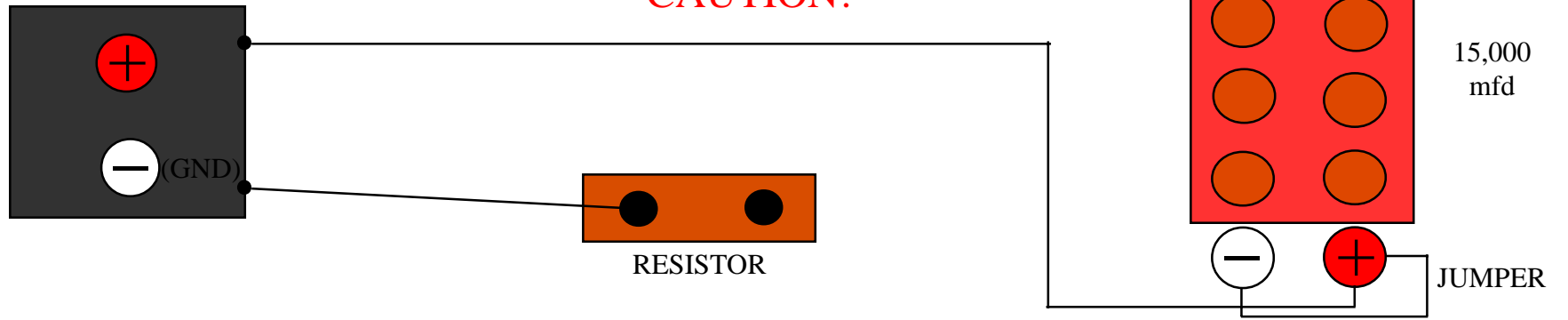

TO CHARGE / AC/DC ON:

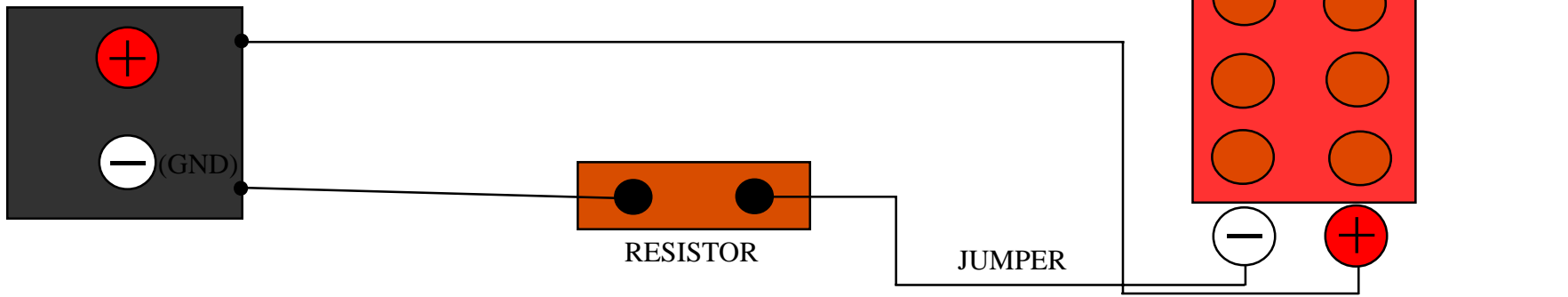

1. CHARGE: VOLTAGE DIAL @ 0
TURN AC ON FIRST FOR 2 min.
TO ALLOW VACCUM TUBES TO
WARM UP. THEN DC SWITCH ON.
2. THEN TURN VOLTAGE CONTROL
TO NO MORE THAN 175. WAIT 3
min. TO CHANGE (AMPS TO 0).
THEN TURN DC OFF.
3. DISCHARGE WITH ROD.
DISCHARGE AGAIN.
DISCHARGE AGAIN.
THEN RETURN TO @ REST.